

H e g n e r

B e l t S a n d e r T B S 5 0 0

Operating instructions



Multicut-1
Multicut-2S
Multicut-SE
Multicut-Quick

Important:

In order to prevent accidents,
read the operating instructions
before commissioning and use.

**Always keep the operating
instructions available by the
machine!**

CE-Confirmation

for

Belt Sander Type TBS 500

- EC-Regulation 89/392/EEC (machine standards), latest alteration by EC-standards 93/68/EEC
- EC-Regulation 73/23/EEC (low voltage standards), latest alteration by EC-standards 93/68
- EC-Regulation 89/336/EEC (electromagnetic compatibility), latest alteration by EC-standards 93/68

The following rules were applied to when constructing and building the machines:

Harmonised standards:

- EN 292-1 - EN 349
- EN 292-2 - EN 60204-1
- EN 294

European Standards and Standard Designs:

- EN 60529 - prEN 31020
- EN 954 - EN DIN 50081-2
- EN ISO 23746 - EN DIN 50082-2

National Standards and Standard Designs:

- VBG 7j

The above machine was tested according to paragraph 3 of the GSG (safety security law) and a "GS-Certificate with the number 971084" was issued by:

Fachauschuß Holz
Prüf- und Zertifizierungsstelle im BG-PRÜFZERT
Vollmüllerstr. 11
D-70563 Stuttgart

Hegner Präzisionsmaschinen GmbH

VS-Schwenningen, 1st November 1997

Werner Broghammer,
Manager

Preface:

The machines **Multicut-1**
Multicut-2S
Multicut-SE
Multicut-Quick

are designed for professional as well as private use.

The machines have been designed exclusively for sawing of wood, plastics, non-ferrous metals, soft iron and mild steel by means of fret saw and piercing sawblades with a length of 130mm (5 in).

This manual of operating instructions is designed to acquaint you with the knowledge required for the commissioning and use of the machine.

You will find important information on the safe handling and proper use of the machine.

Please read these instructions carefully and take special note of the guidelines and warnings!

In case of improper use of the machine and non-observance of the warnings and guidelines given in these operating instructions, the manufacturer's warranty is invalidated.

If you have any questions after reading these operating instructions, please contact your dealer.

Hegner Präzisionsmaschinen GmbH

Symbols and their meaning



This symbol marks text with very important information and in many cases gives information for your safety! It is absolutely necessary that you take note of this information!



This symbol points to texts containing comments, guidelines or tips. It refers to a chapter, sub-chapter, page or picture.



This symbol points to references to supplementary information about the current topic.

- This dot marks the description of operations which you should carry out.

Index:

1.0	Technical information
2.0	Delivery of the machine
3.0	Operating instructions
4.0	Machine use
5.0	Guidelines
6.0	Remaining risks
7.0	Unpacking/Setting up
8.0	Commissioning/De-commissioning
9.0	Changing sawblades
10.0	Sawblade change with internal cuts
11.0	Swivelling the table
12.0	Adjusting the stroke length
13.0	Connecting a dust extractor
14.0	Maintenance/Cleaning
15.0	Repairs/Spare parts
16.0	Application guide lines
17.0	Speed selection
18.0	Operating problems and their causes

1.0 Technical Characteristics

Multicut-1

Depth of throat	365mm
Cutting clearance	50mm
Maximum depth of cut (wood)	50mm
Size of table	435x230mm, 45° swivelling
Depth & width	520x270mm
Blade stroke length	12 and 18mm
Motor	230V, 50 Hz, 80 W power output
Weight	approx. 16 kg nett
Blade length	130mm (5 in)
Suction port	ø 35mm
Mains fuse	3 A or 5 A fuse

Multicut-2S/SE

Depth of throat	460mm
Cutting clearance	65mm
Maximum depth of cut (wood)	65mm
Size of table	435x230mm, 45°/12° swivelling
Depth & width	610x280mm
Blade stroke length	12 and 19 mm
Motor	230V, 50 Hz, 100 W power outp.
Weight M2S/SE	approx. 19kg nett/ 23kg nett
Blade length	130mm
Suction port	ø 35mm
Mains fuse	3 A or 5 A fuse

Multicut-Quick

Depth of throat	560mm
Cutting Clearance	65mm
Maximum depth of cut (wood)	65mm
Size of table	435x230mm 45°/ 12° swivelling
Depth & width	730x290mm
Blade stroke length	12 and 19mm
Motor	siehe Multicut-2S
Weight	approx. 29kg nett
Blade length	130mm
Suction port	ø 35mm
Mains fuse	3 A or 5 A fuse

1.1 Ratings for the extraction system

Exhaust volume when fitted to ø 35mm hose: 70 m³
Existent depression with an air speed of 20m/s: 1666 Pa

The dust emission values, measured according to the precepts for the testing of the dust emission (workpost-related dust concentration) of wood working machines of the professional committee for wood, are distinctly under the presently valid limit of 2.0 mg/m³.

1.2 Emission of Noise

Measurement Conditions:

- prEN 31202 for the workpost-related emission values.
- With the following supplements determined by TC 142 in order to obtain an exactness class better than 3 dB.
- The environmental correction factors K2A respectively K3A are < 4dB.
- The difference between extraneous noise sound level and noise sound intensity level is < 6 dB each metering point.
- K3A is calculated according to annex A, prEN 31204.
- An ashlar-type enveloping surface with 9 metering points is utilised in a distance of 1 m from the reference surface.

Workpiece: pine wood; dimensions 150 x 100 x 20mm (sanded all over)

Tool: Fret Saw Blade

Dimensions: depth 1,5mm - width 1mm.

The determined noise emission values are:

Acoustic capacity level (dB (A))

Idle running: 64,1 dB
Machining: 74,5 dB

Statement to the noise emission levels:

The given values are emission levels and do not correspond in every case to the save working place related values.

Although there is a relation between emission and imission levels, it is perhaps necessary to take additional safety measures.

Factors which have a certain influence to the actual imission level are the duration of the exposure, the kind of work-shop and some other influences.

The acceptable limits do also depend on the different countries. This information should give a better possibility to the user of the machine to classify the hazards and risks.

Source: EN 292-Part 2

The real noise emission can deviate from the given values in a range of 4 dB(A) due to specific influences of the workshop.

2.0 Delivery of the machine

- Check the machine upon receipt
 - Damage to the machine
 - Contents against delivery note
 - Examine the packaging for small parts

If there is any damage or discrepancies contact your supplier immediately!

3.0 Operating instructions



Read the operating instructions carefully before commissioning and using the machine.

If the machine is not used in accordance with the operating instructions the manufacturer's warranty is void.

4.0 Machine use

- This machine has been designed for the sawing of wood, plastics, non-ferrous metals and mild steel by means of fret saw (scroll saw) and piercing sawblades 130mm (5 in) long.



- Use for any other purpose has not been catered for.
- This machine must only be used by persons who have read these instructions and are familiar with the safety requirements and dangers associated with its use.
- The relevant safety procedures outlined in these instructions must be observed.
- Only original HEGNER spare parts must be used.
- Damage which occurs due to the use of spare parts which are not original HEGNER parts, will invalidate the manufacturer's warranty.
- Modifications to the machine or usage for any purposes than those for which the machine was designed will invalidate any liability of the manufacturer.

5.0 Safety guidelines

5.1 General safety guidelines



- Keep people other than the operator away from the machine. Children should only be allowed to use the machine under supervision.
- Do not touch any moving parts.

5.2 Commissioning

- Check that the voltage on the motor plate corresponds with the voltage of the electricity supply.
- Connect a dust extractor.
 - ⇒ 13.0 Connecting a dust extractor.
- Check work area is well ventilated.

5.3 The operator

- In order to minimise the risk of accident with the machine, read the operating instructions carefully.
- Never work under the influence of drugs, alcohol or medicine.
- Never use loose fitting clothing. Always use eye goggles.
- Do not wear jewellery.

5.4 Before starting work

- Insure that the machine is switched off.
 - ⇒ 8.3 Switching the machine off
- Insure that the fitted sawblade is appropriate for the work.
- Check that the sawblade is tensioned.
- Check that all appropriated guards are fitted correctly.

5.5 During work

- Only remove swarf dust and chips when the machine is switched off.
- In case of a power failure return the power switch to the OFF position.

5.6 After work

- Switch the machine off and pull the mains plug.

6.0 Remaining risk

Even when adhering to all the relevant safety rules the following remaining risks can occur because of the nature of the machine.

- Touching the sawblade
- Breakage of the sawblade
- Touching live parts due to
 - damaged terminal box
 - damaged capacitor
 - damaged cable
- Hearing impaired due to working for long periods without ear protection.
- Inhaling dust and endangering your health.



7.0 Unpacking & setting up

7.1 Unpacking

⇒ Picture 7-1

Lift the machine out of the packing as shown in the picture.
Do not lift by the upper arm (1)

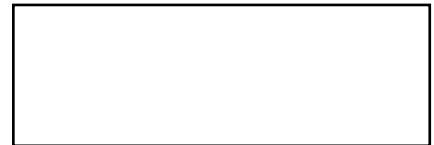

Picture 7-1

7.2 Setting up

⇒ Picture 7-2

Place the machine on a stable surface which is solidly constructed and without loose joints with room to approach the machine from the front with plenty of free space.



Picture 7-2

- The height of the surface should be sufficient to allow the operator to use the machine with his/her back in an upright position. The elbow of the operator should be at the height of the machine table surface.

Secure the machine to the surface

- either with two coach screws, secured from the top through the two holes (1) in the baseplate of the machine
- or with 3 M10 bolts screwed through from under the mounting surface into the threaded holes (2).

We recommend our machine stand (optional accessory), especially constructed for out fret saws.

7.3 Ambient conditions

The machine should be installed in a place which is

- vibration free
- dry
- free from gas and vapour
- free from mineral dust
- well ventilated

7.4 Electrical installation



The electrical power supply must conform to the standards required by law and match the power requirements of the machine!

⇒ 1.0 Technical Characteristics

- **Make sure that the mains switch on the machine is in the OFF position!**
⇒ 8.3 Switching the machine off
- Connect the mains plug to the supply socket.

Make sure that the lead

- does not foul the work
- will not cause operator to trip up

8.0 Commissioning/De-commissioning

8.1 Commissioning the machine

We assume that



- you have read the proceeding instructions (particularly 5.0 Safety guidelines). If not, please do not now before proceeding from here!
- the machine has been installed and connected to the mains properly
- that all tools and materials have been removed from the work area
- the machine is undamaged and correctly mounted.

- Check that the clamped in sawblade is straight!

A bent sawblade is unservicable and should be replaced with a new one.

⇒ 9.0 Changing a sawblade

8.1.1 Tensioning the sawblade

⇒ Picture 8-1

- Check that the quick action blade tensioning lever (1) is in the tensioned position. (Not with the Multicut-1 machine)
- Tension the sawblade using the tensioning knob (2)



Picture 8-1

Turn the tensioning knob (2) clockwise to increase the tension until the blade is tensioned. When the blade is tensioned correctly you should be able to move the blade about 1mm forward and back at table level.

8.1.2 Untensioning the sawblade

⇒ Picture 8-1

- **Untension the sawblade only when the machine is switched off!**

Untension the sawblade by pulling the quick action tension level (1) forward on the Multicut-2S, -SE and Quick. On the Multicut-1 turn the tensioning knob (2) about three complete turns anti-clockwise.

8.1.3 Vacuum cleaner/dust extraction system

⇒ Picture 8-1

- Put the end of the dust extractor hose into the tapered port (3) so that it fits tightly.



Take care that protection hood (4) is folded upwards!

8.2 Switching the machine on

⇒ Picture 8-3

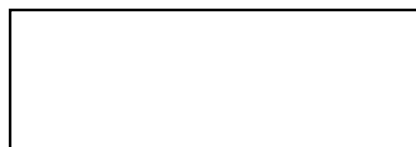

Picture 8-3



Attention:

The machine will start to function as soon as it is switched on!

- Remove all tools, workpieces, dust and debris from the work table!
- Connect the machine to the mains supply and switch on the machine with the main switch (1) pressing the rocker at the bottom (I).
- Switch on the dust extractor.

8.3 Switching the machine off temporally

⇒ Picture 8-4

- Switch the machine off using the main switch (1) by pressing the rocker at the top (O).
- Switch off the dust extractor.
- Remove all tools, workpieces, dust and debris from the work area!



Picture 8-4

8.4 Taking the machine out of operation

when you have finished using the machine and are leaving the workshop:

- Ensure that the machine is switched off at the main switch (1) by pressing the rocker at the top (O) and isolate from the power supply.



- Untension the sawblade.
- Remove all tools, workpieces, dust and debris from the work area!

9.0 Changing the sawblade

9.1 Isolating the machine

⇒ 8.4 Taking the machine out of operation

9.2 Untension the sawblade

⇒ Untensioning the sawblade

Carry out this procedure even if the blade is broken.

9.3 Tilt the protection hood down

⇒ Picture 9-1

- Fold the protective hood (1) down
- Remove any chips from the protective hood.

9.4 Removing the blade from the machine

⇒ Picture 9-2

- Turn the knurled screw anti-clockwise until it is just below the underside of the blade retainer.

⇒ Picture 9-3

- Press the upper arm gently downwards until the upper blade clamp can be slipped out of the clamping fixture.

⇒ Picture 9-4

- Press the clamping spring on the bottom arm down and take the blade and its clamps out of the machine.

9.5 Taking the sawblade out of the clamps

⇒ Picture 9-5

- Place the sawblade clamp into the clamp holder at the front right of the work table.

⇒ Picture 9-6

Open the clamp with the clock key until the blade can be removed easily.

9.6 Putting a new sawblade into the blade clamps

⇒ Picture 9-5

- With the teeth pointing to the right and to the rear, lay the new sawblade in line with the centre of the clamp "V" and feed it straight into the clamp.

- Slide the sawblade in until it touches the square headed tightening bolt, and then pull it back by about 1mm. This stops the blade distorting as you tighten the blade clamp.

- Tighten the blade clamp using the clock key till the blade is secure in the blade clamp. Do not over-tighten!

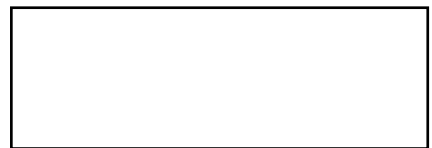

Picture 9-1



Picture 9-2



Picture 9-3

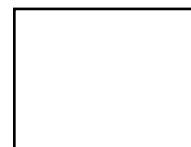

Picture 9-4

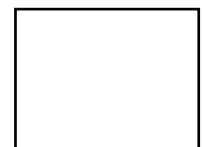

Picture 9-5



Picture 9-6



Picture 9-7

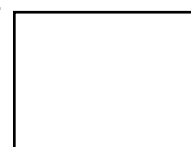

Picture 9-8



Picture 9-9



⇒ Picture 9-7

- Clamp a second blade clamp to the other end of the sawblade.

⇒ Picture 9-8

Make sure that the head of the tightening screws on both clamps is on the same side of the blade.

9.7 Fixing the sawblade and blade clamps into the machine

⇒ Picture 9-4

- Ensure tha the teeth are facing forward and downward.
- Clip the lower blade clamp into the lower arm.
- Hold down the top arm and set the top blade clamp into the upper arm.

⇒ Picture 9-9

- Adjust the upper knurled screw until there is a 1mm gap between the screw and the top of the blade clamp.

10.0 Making internal cuts

In order to make internal cuts in a workpiece, the workpiece must be pre-drilled to allow the sawblade to pass through. It is recommended to use the piercework clamp for making internal cuts.

10.1 Taking the machine out of operation

8.4 Taking the machine out of operation

10.2 Securing the piercework clamp

⇒ Picture 10-1

- Place the piercework clamp into the upper arm and lock it into position with the knurled screw.



Picture 10-1

10.3 Placing the sawblade through the workpiece

- Move the sawblade forward sufficiently to place the sawblade through the pre-drilled hole in the workpiece. With large workpieces you may have to unclip the bottom clamp from the bottom arm to ease the sawblade through the workpiece.

10.4 Clamping the sawblade into the piercework clamp

⇒ Picture 10-2

- Hold the top arm down and place the top of the sawblade into the front of the piercework clamp. Do not put much pressure on the sawblade or you will distort the sawblade in the clamp.
- Tighten the piercework clamp using the knurled aluminium knob on the side of the clamp.



Picture 10- 2

10.5 Tensioning the sawblade

⇒ 8.1.1 Tensioning the sawblade



- Position the workpiece so that it will not touch the sawblade when you switch the machine on.

Note:



When using the piercework clamp it should always be locked in position on the top arm to save time when changing the sawblade.

11.0 Angling the table top

⇒ Picture 11-1



By swivelling the table top you can adjust the cutting angle to a maximum of 45°.



Picture 11- 1

11.1 Taking the machine out of operation

⇒ 8.4 Taking the machine out of operation

11.2 Swivelling the table top

- Take out the table insert (2)
- Loosen the star knob (1) by turning about one rotation anti-clockwise.
- Swivel the table top to the desired angle using the protractor scale and tighten the star knob clockwise.
- Reposition the table insert (2) in the table.

12.0 Adjusting the stroke length

 The machine leaves the factory set to the long stroke length. This is the best setting for the vast majority of work on the fretsaw (scrollsaw).

 For working in extremely thin or light materials, such as veneers and thin sheet metals, shortening the stroke gives more control and smoothness of operation. The danger of breaking thin blades is reduced.

12.1 Taking the machine out of operation

⇒ 8.4 Taking the machine out of operation

12.2 Taking off the side guard plate

⇒ Picture 12-1

Remove the screw (1) using the hexagonal socket screw key (Allen key) and take off the side guard plate (2).



Picture 12 - 1

12.3 Securing the flywheel

⇒ Picture 12-2

Put the steel pin into the side bore in the flywheel.

12.4 Detaching the link and bearing assembly

⇒ Picture 12-2

- Hold the steel pin (1) with one hand - preventing the rotation of the flywheel
- Loosen the pivot screw (2) anti-clockwise using the open ended spanner (3) (with the Multicut-1 use a 3mm Allen key).



Picture 12 - 2

12.5 Adjusting the stroke length

⇒ Picture 12-3

- Lightly push the link and bearing (1) to one side. Behind you will see two threaded holes in the flywheel.
- To adjust
 - for a short stroke, replace the pivot screw into the threaded hole (3) nearest to the centre point of the flywheel
 - for a long stroke, replace the pivot stroke into the threaded hole (4) which is further from the centre point of the flywheel.

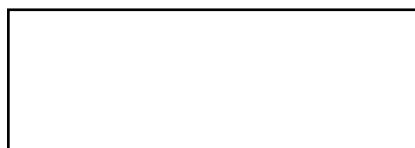

Picture 12 - 3

12.6 Tightening the pivot screw of the link and bearing assembly

⇒ Picture 12-4



Before you re-tighten the pivot screw through the link and bearing into the flywheel, check that the spacer washer is in position between them.

- When tightening the pivot screw hold the flywheel with the steel pin to prevent it turning.



Picture 12 - 4

13.0 Connecting a dust extractor



Certain types of wood and wood sheet materials etc. produce harmful dust emissions during machining. For this reason the machine should be connected to a dust extractor. With long and frequent use in a manufacturing or educational situation the dust extractor should be wired so that it comes on automatically when the machine is switched on.

13.1 Connection

⇒ Picture 13-1



The machine is fitted with an extraction port for fitting to a dust extractor or vacuum cleaner.



Picture 13 - 1

- Put the end of the dust extractor hose into the tapered port (1) so that it fits tightly.

13.2 Adjustment of the upper extraction tube

⇒ Picture 13-2

- Loosen the clamping handle (1)
- Adjust the upper extraction tube until it is just above the height of the workpiece and 8mm to the rear of the blade.
- Tighten the clamping handle (1)



Picture 13 - 2



If you wish to work without dust extraction the sawdust can be blown free of the work line by pulling the upper extraction hose (4) from the extraction port (5) and inserting in the back of the bellows base (3).



The machine should only be used without dust extraction in the open air!

In closed room, dust extraction should always be used! (See 13.0 Connecting a dust extractor)

14.0 Maintenance/Cleaning

- The machine requires very little maintenance! Only the upper and lower arm pivot bolts must regularly (about every 10 hours of operation) be lubricated with a fine, non-resinous oil (e. g. sewing machine oil).

14.1 Oiling the arm pivot bolts

⇒ Picture 14-1

- Brush off all dust that has accumulated round the pivot bearings (1)!
- Oil both pivot bolts with a light oil. Put a drop of oil onto the pivot bolt on each side of the arm at the spots marked with the arrows.

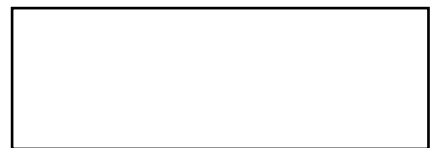

Picture 14 - 1



The tension rod (2) must not be oiled or greased!

14.2 Sight check



- Carry out a visual check at regular intervals with the machine switched off. Check all parts of the machine, especially

- the mains plug
- the mains cable
- the switch box for damages!

- If damage is found, take the machine out of operation immediately and have an expert repair made with original spare parts!

14.3 Cleaning



- The machine should be cleaned regularly when required!
- Dust and chips should not be allowed to accumulate on the machine!

14.3.1 Taking the machine out of operation

⇒ 8.4 Taking the machine out of operation

14.3.2 Cleaning the machine

- Clean the machine by removing the dust and chips with a vacuum cleaner.
- Remove the side guard plate and remove the dust and chips accumulating behind it.
- Remove any remaining accumulations with a soft brush (a paint brush is ideal).

- **Do not use any**



- combustible
- etching
- scouring cleaning agents!

- Prevent liquid or dampness from penetrating into the machine, especially to the electrical parts!
- If liquid or dampness has penetrated the electrical parts do not connect the machine to the electrical supply!
- In this case contact your dealer, distributor or the manufacturer.

15.0 Repair/Spare parts



This instruction manual does not contain any instructions for repairs!
The repair and/or exchange of parts is done at your own risk!

- Please observe the following guidelines without fail.

15.1 Repairs



- Do not repair or replace any defective electrical parts!
 - These parts must be replaced by original parts from the manufacturer!
 - The replacement of electrical parts must only be carried out by the manufacturer, authorised dealer/distributor or a qualified operative (e.g. electrician).
 - An improper repair or replacement of electrical parts may cause death or injury due to electrical shock or cause electrical fires!

The person repairing the machine is held liable for all injuries caused in this way!

- Defective mechanical machine parts
 - should normally be replaced only by the manufacturer/dealer/distributor or an operative with the relevant mechanical knowledge
 - can be exchanged by the user with original parts from the manufacturer, if the user has the required mechanical knowledge
 - The person repairing the machine is held liable for all injuries or damage caused by improper repair!



- **If you want to repair the machine yourself,**
 - switch off the machine and unplug from the electrical supply before commencing repair.

16.0 Application guidelines

16.1 Choice of sawblade with regard to the material to be cut

⇒ Table on the side guard plate of the machine



Important:

When sawblades become blunt they should immediately be replaced with a new sawblade. This applies particularly when cutting iron or steel. The full cutting capacity and precision is only achieved if the recommended quality and grade of sawblade is used.



Useful guide:

If for economic reasons you wish to continue to use a sawblade that is becoming blunt, you can fix, with double sided tape, a false table of at least 20mm thickness to the machine table and continue sawing on top of this. This way you can use the portions of the sawblade not used previously.



Working with plastic materials:

To stop the plastic fusing together behind the sawblade, cover the desired cutting line with brown parcel tape or another adhesive PVC tape.

16.2 Feed pressure

The feed pressure you apply to the workpiece must be directed towards the front of the sawblade. Failure to do this will cause the workpiece to chatter or break the sawblade. Some thick workpieces require a strong feed pressure!

16.3 Use of a fence

It is not possible for a fretsaw (scrollsaw) to be used with a fence.

If you attempt to use the fretsaw (scrollsaw) with a fence the blade will depart from the desired cutting line and break as side pressure is applied to the blade. This is due to the right hand bias of all fretsaw and piercing sawblades.

Exact sawing is achieved by

- a sharp sawblade
- a thin, clear cutting line
- good lighting

16.4 Straight cuts

Hold the workpiece inclined to the right of the table about 1° to 5°! (The angle depends on the material, the type and sharpness of the sawblade and the blade tension).

16.5 Guidance for cutting metals

- Remove any burrs from the edges of metal workpieces. Ensure that all sides are smooth.
- Attach small or thin workpieces (e. g. thin sheet metals) to a plywood or hardboard panel about 5mm thick, with double sided adhesive tape. Alternatively place the workpieces between two plywood pieces that are bolted together so that the workpiece cannot shift.
- Saw the workpiece and the plywood together (beware using a blade which is too coarse).

- **Select wood sawblades for**



- soft non-ferrous metal e.g.
- aluminium sheet
- soft copper sheet
- soft brass sheet

- Use grades 1, 5 or 9 from the sawblade pack depending on the thickness of metal to be cut.

- It is advisable to wipe the cutting line with light lubricating oil before sawing.

- **Select metal sawblades for**

- hard non-ferrous metals and ferrous metal e.g.
- duralumin sheet
- hard brass sheet
- steel sheet

- Use grades 1, 5 or 9 from the sawblade pack depending on the thickness of metal to be cut. For thick sheet of 10mm thickness it is better to use number 12 (or higher) metal cutting sawblades.



- Smear cutting oil or paste around the cutting line before starting to saw.

- Despite using blades of best quality iron and steel wear out sawblades quicker, depending on the degree of hardness.

17.0 Selection of cutting speed (variable speed machines only)



- Higher speed are preferred for cutting most timber and plastics
- Slower speed is best used on metals, thin materials or extremely fine, intricate fret work.
- High speeds give better cutting performance: slower speeds give greater blade life. This trade-off should always be considered when selecting cutting speed.

18.0 Operating mistakes and causes

Effect	Cause	Remedy
Workpiece catches or jumps.	Too much feed pressure on the workpiece Sawblade is in the machine upside down. Turning a sharper radius than the sawblade will comfortably allow at the feed speed.	Slacken off the feed pressure. Give the blade time to cut at its own speed. Put blade in correctly (see 9.5) Slow down, ease the sawblade slowly round tight corners.
Sawblade does not appear to cut well.	Blunt or wrong sawblade. Poor quality sawblade. Insufficient feed pressure.	Replace with sharp and/or correct sawblade! Use high quality German sawblades! Increase feed pressure
Sawblade pulls out of clamp.	Clock key screw insufficiently tightened.	Increase clamping pressure! If the sawblade continues to pull out-replaceclamp.
Sawblade running hot and burning or tear	Too strong a feed pressure, turning too quickly in thick timber. Too fine a sawblade in close grain timber. Blunt sawblade.	Reduce feed pressure! Choose coarser sawblade! Replace sawblade.
Hard to follow marked lines.	Too strong a feed pressure. Blunt or incorrect grade of sawblade Not enough support on thin materials	Reduce feed pressure! Replace sawblade or choose finer blade! Back thin sheet with a 4mm plywood or hardboard sheet.
Cutting face is bowed.	Insufficient blade tension. Blunt sawblade and too strong a feed pressure. Too fine a sawblade.	Increase blade tension! Replace with new sawblade and decrease feed pressure! Utilise a coarser sawblade!
Cutting face is not vertical	Table top not at 90° to the blade or table adjustment screw not tightened	Align table top correctly with a square and tighten screws!
Underside of workpiece splinters	Wrong type of sawblade Worn table insert	Utilise reverse tooth sawblade! Change table insert (included with standard accessories)

HEGNER Multicut - 1

Spare parts

When ordering spare parts please refer to the part numbers mentioned on the explosion drawing.

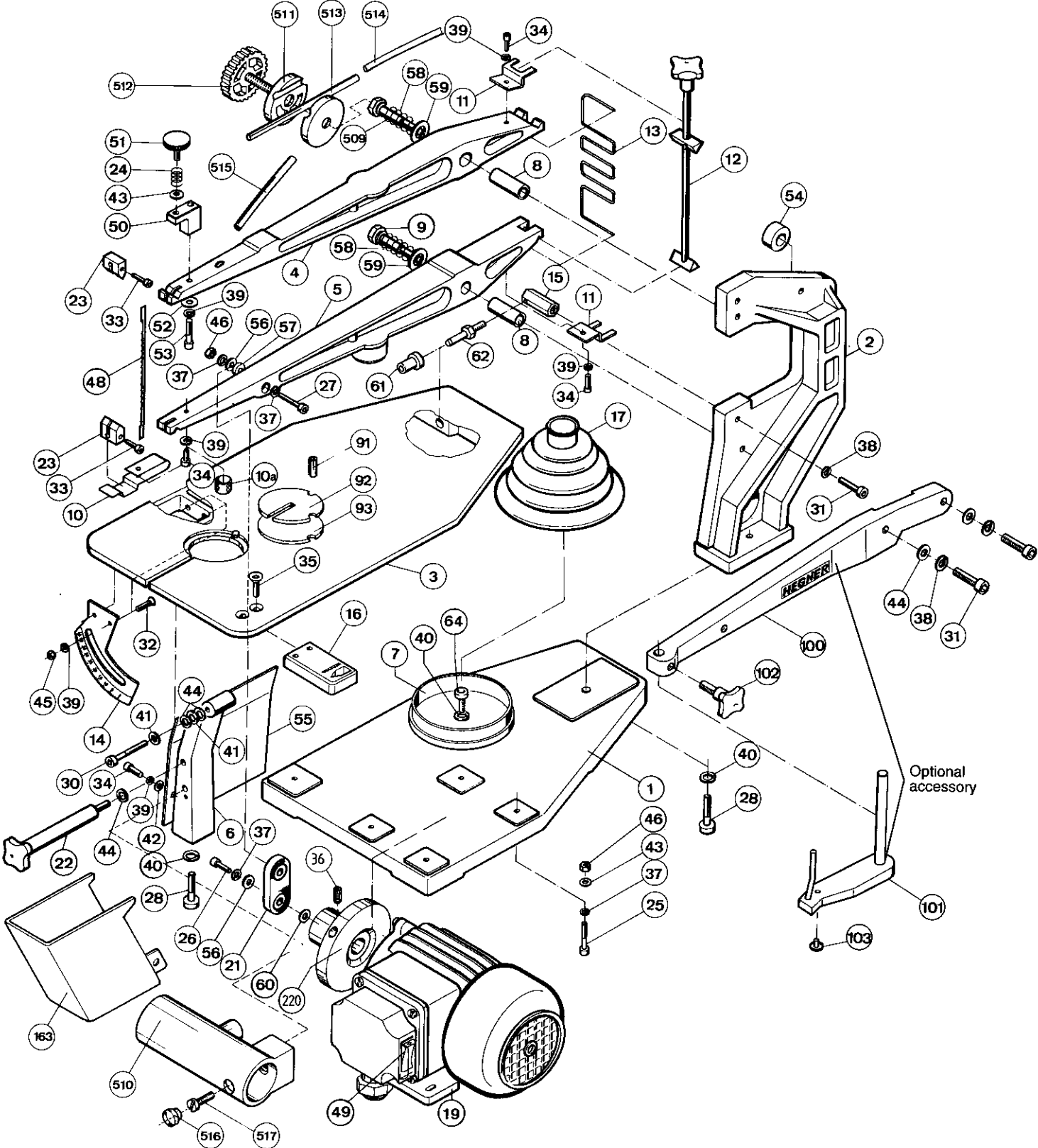

HEGNER Multicut - SE

Spare parts

When ordering spare parts please refer to the part numbers mentioned on the explosion drawing.

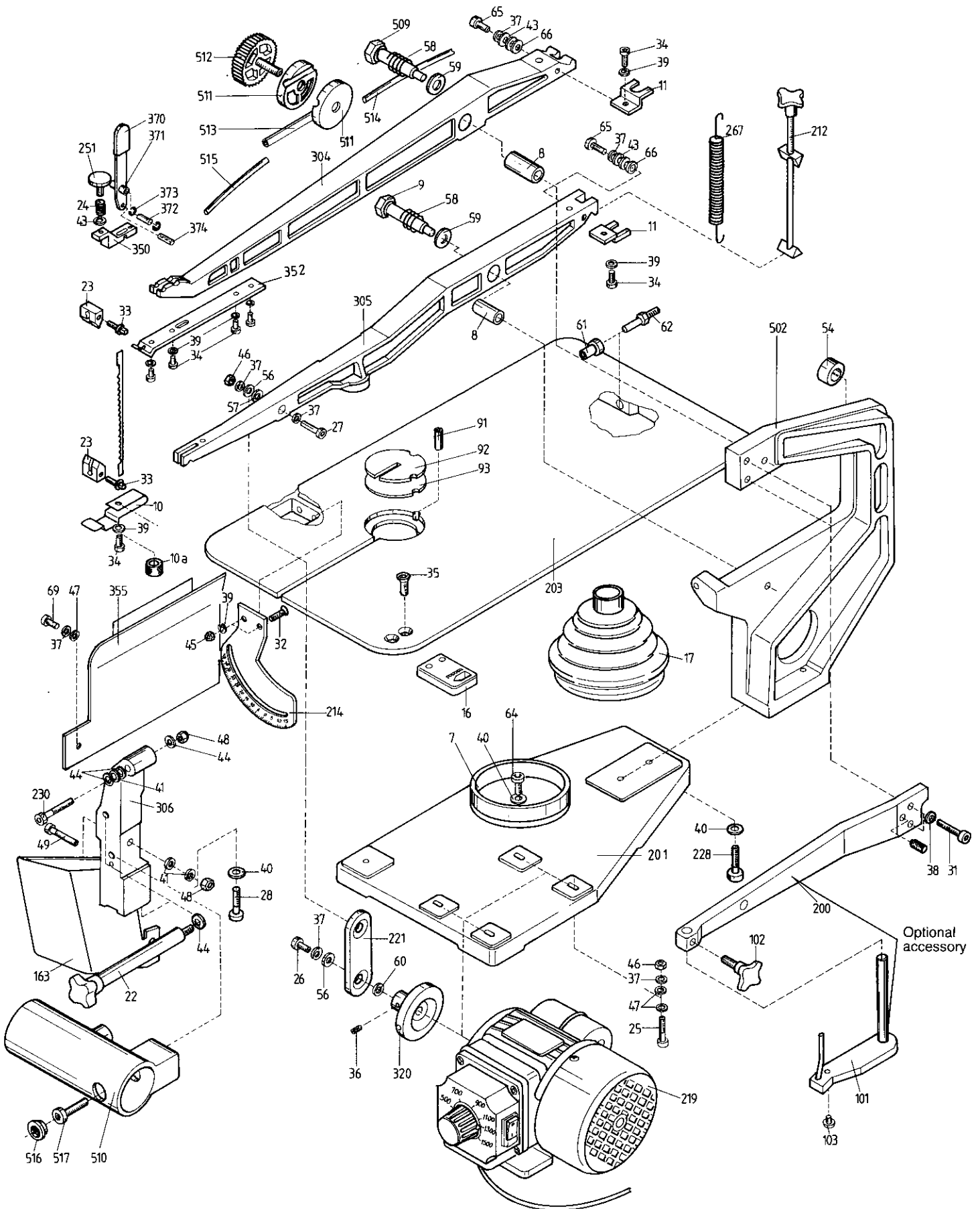

HEGNER Multicut - Quick

Spare parts

When ordering spare parts please refer to the part numbers mentioned on the explosion drawing.

